

Compact overfill detector MAXIMAT CX



SAFETY INSTRUCTIONS

- Installation, commissioning and maintenance may only be performed by qualified personnel!
- Only connect the device to the voltage specified in the technical data or on the type plate!
- Disconnect the device from the power supply during installation/maintenance work!
- Only operate the device under the conditions defined in the operating instructions!

DESCRIPTION

The MAXIMAT CX compact overfill detectors are level limit switches designed to prevent overfilling of tanks containing media hazardous to water. When the probe is touched by an electrically conductive medium, the integrated electronics react and the permanent output signal is interrupted.

This signal can be output by the plant control system as an acoustic or visual alarm signal and, if necessary, used for emergency shutdown of the filling process.

APPLICATION

The level sensor is suitable for media whose impedance is $<5\text{k}\Omega$ or whose coupling capacitance to ground is $>50\text{pF}$. The media must not form insulating or conductive deposits.

TECHNICAL DATA

Operating principle	Capacitive-high frequency, fail-safe
Operating/ambient temperature	$-20\dots+60^\circ\text{C}$
Operating pressure	atmospheric, 0.8...1.1bar
Connection head	PBT glass fiber reinforced
Protection class	IP65 according to EN 60 529
Supply voltage	15...27V DC
Connection power:	$<1\text{W}$
Cable length measuring circuit	Max. 300m, min. wire cross-section 0.5mm^2
Outputs	Floating reed relay contact for low voltage (contact opens on alarm) Max. 50V AC/DC, max. 0.5A, max. 10VA, e.g. for operation of coupling relay or PLC, signal device TC4 or supply isolator CST Two-wire alarm evaluation with transmitter MAXIMAT SHR C

Important: Simultaneous operation of both outputs is not intended!

Terminals	Screw connection, cable cross-section max. 2.5mm^2
Input	For external test button (connection to terminal T and terminal C) Test button contact closed: Test alarm is triggered

Note: The function check by the external test button is not a substitute for the regular function checks required by the country!

CE mark: The device fulfills the legal requirements of the applicable EU directives.

BAMO INTERNATIONAL

22, Rue de la Voie des Bans · Z.I. de la gare · 95100 ARGENTEUIL

Tel +33 (0)1 30 25 83 20 Web www.bamo.eu

Fax +33 (0)1 34 10 16 05 E-mail export@bamo.fr

Compact overfill detector
MAXIMAT CX

30-05-2023

M-556.06-EN-AC

LEV

556-06/1

SIGNALING

LED (green) on the connection board (only for version with connection head):

Operation	LED lights up
Alarm / Fault	LED off

MAINTENANCE

When used as intended, the device is maintenance-free.

FUNCTION TEST: before installation / during commissioning / during revisions

Method 1

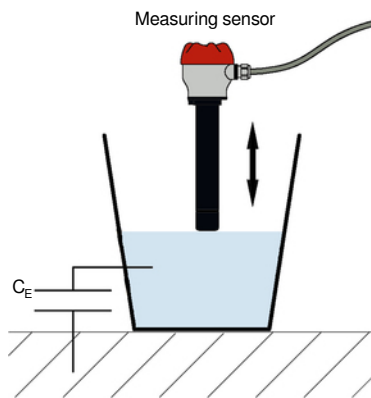

The bucket is on the floor.

- Fill a bucket (plastic or metal) with the process medium or water (at least 5 liters) and place it on the floor
- Immerse the sensor several times and remove it again!
- Check the switching state of the measuring circuit!

Method 2

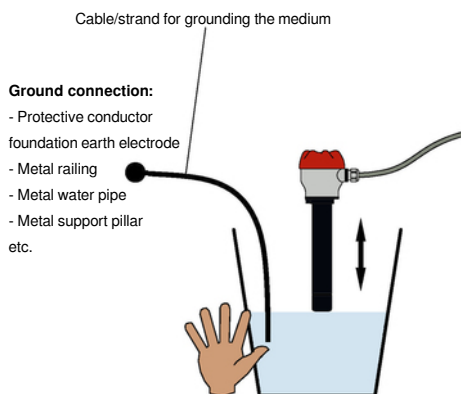

The bucket is not on the floor.

- Fill a bucket (plastic or metal) with the process medium or water (at least 5 liters)!
- Ground the filled medium with a cable or stranded wire!
- Or grab the bucket with your hand from the outside!
- If the process medium is not harmful to health, a finger can also be held in the medium. When doing so, immerse the sensor several times and remove it again!
- Check the switching state of the measuring circuit!

BAMO INTERNATIONAL

22, Rue de la Voie des Bans · Z.I. de la gare · 95100 ARGENTEUIL

Tel +33 (0)1 30 25 83 20 Web www.bamo.eu

Fax +33 (0)1 34 10 16 05 E-mail export@bamo.fr

Compact overfill detector
MAXIMAT CX

30-05-2023

M-556.06-EN-AC

LEV

556-06/2

ELECTRICAL CONNECTION

