



## Cable-Pull Fill Level Indicator **STRINGLINE® SFA...PVC**

### General:

The SFA is used for the acquisition of fill levels in tanks to which no interior components may be installed, and to which no entry fittings for other indicators may be attached at the side, for example storage tanks in accordance with WHG.

The fill level is conveyed to the PVC standpipe in reverse proportion with the deflection pulleys via the cable, and is thus made visibly discernible.

Thanks to a magnet which has been integrated into the counterweight, the fill level can be simultaneously monitored with individual BSM limit switches.

Simultaneous display and regulation of fill levels can be accomplished by means of the NIVOMAT FS3 level sensor, and the appropriate NIVOMAT FM1019 remote indicator.

### Installation:

The SFA ... PVC cable-pull fill level indicator is shipped partially assembled only, so that the transparent PVC pipes can be precisely adapted to the tank dimensions.

### Please Observe the Following during Installation!

Only non-magnetic fasteners may be used for mounting the outer standpipe. If magnetic pipe clamps or screws are inadvertently used, the magnetic counterweight may stick at the corresponding locations, or functioning of the limit switches or the level sensor may be impaired.

The standpipe must always be mounted vertically.

Feed the cable between the deflection pulleys and the guide bars (see drawing).

The cable must travel over the centre of the conical pulley.

### Gluing the Pipe Joints:

After the transparent PVC pipes have been adapted to the tank dimensions, all of the joints shown in the accompanying drawing must be glued with an appropriate PVC adhesive (e.g. TANGIT).

### Installation Sequence:

1. Saw the PVC pipes so that they correspond to the tank dimensions and check for correct fit.  
**Caution: Do not yet apply adhesive!**
2. Feed the cable through the unglued pipes and deflection pulleys.
3. Assemble the pipes in accordance with the drawing and mount to the tank.
4. Determine cable lengths and cut off accordingly.  
Caution: Do not cut too short!
5. Dismantle the SFA, but do not remove the cable from the pipes.
6. Glue the pipes at the points indicated in the accompanying drawing.
7. Fasten the float and the counterweight to the cable.
8. Mount the SFA to the tank again.
9. Check to make sure that the actual tank fill level corresponds with the display scale, and correct the cable length if necessary.  
In order to correct the cable length, remove the externally mounted, transparent PVC pipe by loosening the union, pull out the counterweight and shorten the cable as required.



**IER** Meß- und Regeltechnik  
Eberhard Henkel GmbH  
Innstrasse 2  
68199 Mannheim

Tel.+49 (0)621 84224-0 • Fax:+49 (0)621 84224-90  
e-Mail: [info@IER.de](mailto:info@IER.de) • Internet: [www.IER.de](http://www.IER.de)

# Cable-Pull Fill Level Indicator **STRINGLINE® SFA...PVC**

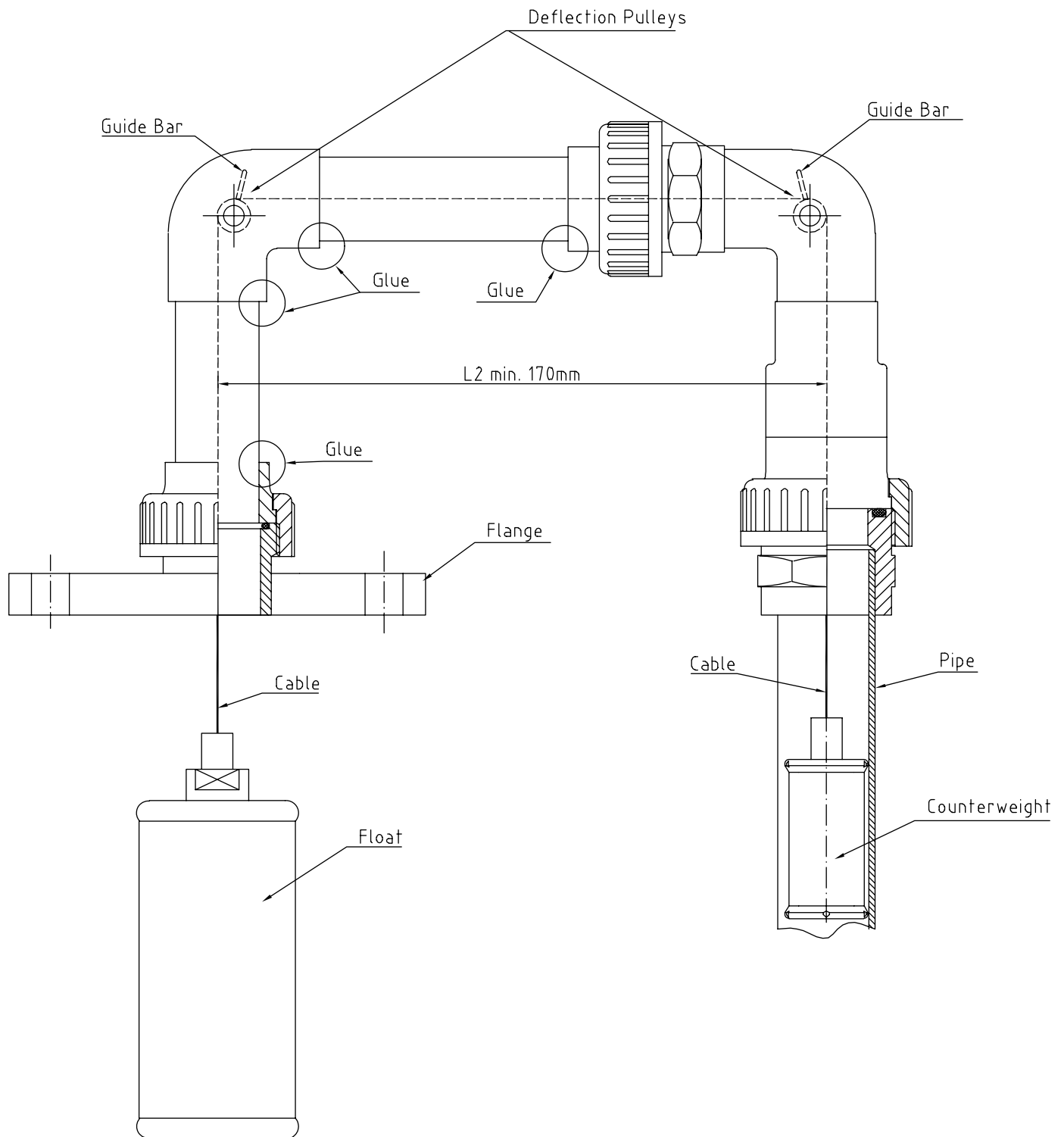

	Standard	Alternative
<b>Float</b>	PP, 78 dia. x 130, 540 gr.	PP, 98 dia. x 87, 610 gr.
<b>Counterweight</b>	GG 401A, 39.8 dia. x 96, 160 gr.	GG 501A, 39.8 dia. x 96, 190 gr.
<b>Cable</b>	PP, 3 mm dia., must be cut to length on-site	
<b>Pipe</b>	PVC, transparent, 50 dia. x 2.4	PVC, transparent, 63 dia. x 3.0
<b>Flange</b>	DN 80 PN 10 SFA 50 F8 PVC	DN 100 PN 10 SFA 50 F9 PVC