

Magnetic Float Switch  
MNR 7....

**Functional Principal:**

Magnetic float switches are used to control and monitor liquid levels in a wide variety of applications.

They consist of a float containing a magnet which is guided by a vertically installed pipe. Changes in liquid level cause the float to move either up or down. The magnet activates reed contacts which are integrated into the pipe.

**Applications:**

Media must be of low viscosity.

Contamination such as clots of fat, crystallised materials, the formation of deposits with sticky media, solid particulates and magnetic metal chips result in interference. The use of magnetic float switches is not advisable for media of this type.

Vibration and impact influence the detent torques in bistable reed contacts. Monostable reed contacts or other measuring methods (conductive or capacitive) are used for applications which are subject to vibration and impact.

**Electrical Data, Contacts:**

The magnetic float switches are equipped with up to 6 contacts each depending upon model.

The following switching contacts are available:

Type	Contact Type	Switching Capacity	Nominal Voltage
S	monostable, NC	10 VA / 10 W	24 V AC/DC
O	monostable, NO	10 VA / 10 W	24 V AC/DC
W	monostable, changeover	10 VA / 10 W	24 V AC/DC
M	monostable, changeover	60 VA / 40 W/1 A	230 V AC
B	bistable, changeover	60 VA / 40 W/1 A	230 V AC

Table 1: Electrical Data

**Switching Capacity:**

Monostable Reed Contact:

A **monostable** contact performs like a **momentary contact pushbutton**. It is only activated as long as it is under the influence of the magnetic field. If the float moves away from the contact, it returns to its normal position. A setting ring can be used to prevent overshooting or undershooting of the monostable contact.

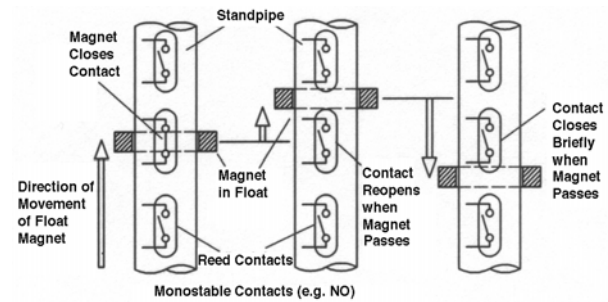

Bistable Reed Contact:

A **bistable** contact performs like a **switch**. It is activated when subjected to the influence of the magnetic field. The switch position remains unchanged, even if the float continues on in the same direction. It returns to its original position when the float passes by in the other direction.

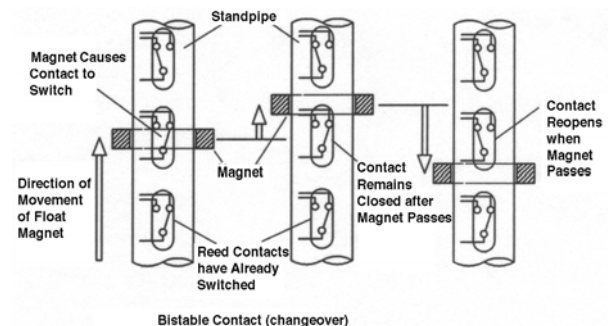

# Installation and Operating Instructions Magnetic Float Switch (magnetic liquid level regulator) MNR 7....

## Electrical Load

Reed contacts are extremely sensitive to over-load.

Even brief overloading beyond indicated maximum values results in destruction. The diagram shows allowable maximum switching current related to applied voltage:

## Contact Protection Measures:

Switching Capacity Hyperbole

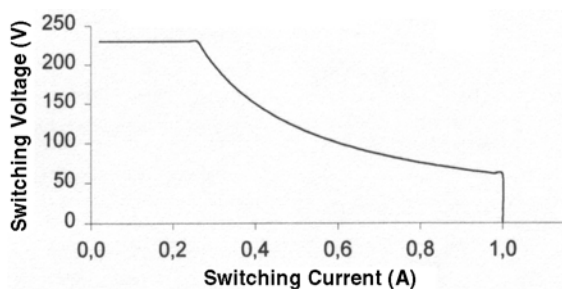

When inductive direct current loads are switched, e.g. with mechanical contactors or relays, increased breaking currents occur which result in interference such as welding of the contacts. For this reason, so-called freewheeling diodes must always be used in such cases.

RC circuits must be implemented for the switching of inductive, alternating current loads.

Inrush current ( $5$  to  $10 \times I_{nom}$ ) must be taken into consideration when incandescent lamps are switched.

Please call us for further information on this subject, or request our data sheet number SU0101. Devices with type S, O and W reed contacts may only be operated with IER type KSR1S.. contact relay.

## Safety Precautions:

Magnetic float switches which are installed into containers whose liquid content or metal walls may be contacted by persons may only be operated with safety low-voltage in accordance with VDE0100/5.73§8. The KSR1S... contact relay should be used in such cases.

## Installation:

Magnetic float switches may only be installed vertically.

The float can be removed for installation. The retaining nut and the limit stop disc at the bottom of the standpipe must be removed to this end. Please observe that the word "TOP" must always appear at the top of the float during assembly. The lettering "TOP", which appears on stainless steel float spheres, may not be upside-down.

## Electrical Connections:

MNR7 magnetic float switches are shipped with an unfinished cable end or a terminal housing depending upon model.

MNR7 devices are equipped with the necessary contact types in an applications specific fashion. Because there are so many possible combinations, an individual wiring plan is included with each device

## Example: Wiring Plan with 4 NC / NO Contacts

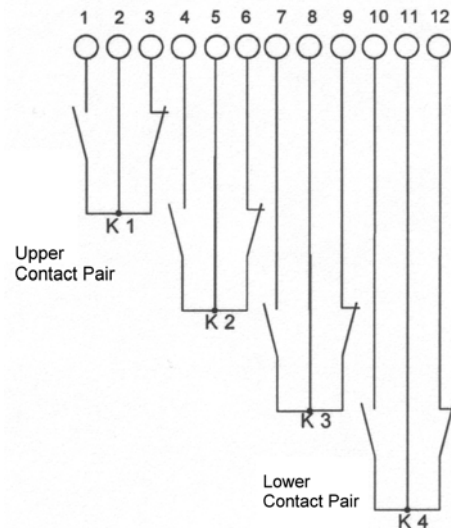

IER Meß- und Regeltechnik  
Eberhard Henkel GmbH  
Innstrasse 2  
D-68199 Mannheim, Germany

Tel.+49-(0)621-84224 0 • Fax:+49-(0)621-84224 90  
e-mail: [Info@IER.de](mailto:Info@IER.de) • Internet: [www.IER.de](http://www.IER.de)

## Technical Data:

Type	MNR7 / 5	MNR7 / 10	MNR7 / K4	MNR7 / K8	MINIMAX
<b>Material for parts which come into contact with the process</b>	stainless steel 1.4571 PP	stainless steel 1.4571	PVC PP	PE-HD PVC PP PVDF	stainless steel 1.4571 PP
<b>Connector cable:</b>	PVC / silicon rubber cable, 0.5 mm <sup>2</sup>	-	PVC cable 0.5 mm <sup>2</sup>	-	PVC / silicon rubber cable, 0.5 mm <sup>2</sup>
<b>Terminal housing</b>	IP65 PBTB Alu (optional)	IP65 PBTB Alu (optional)	IP65 PBTB	IP 65 PBTB	PVC cable 0.5 mm <sup>2</sup> IP65 PBTB
<b>Connector plug</b>	die-cast device plug connector DIN 43650	die-cast device plug connector DIN 43650	die-cast device plug connector DIN 43650	die-cast device plug connector DIN 43650	-
<b>Process connector</b>	G3/8" or G2" flange DN 65	G1", DN 100 flange	G1/2" / retaining nut G1 1/4", flange DN 40	G1", DN 80 flange	G1/8", G1",
<b>Length</b>	100 to 1000 mm	200 to 3000 mm	100 to 500 mm	130 to 1500 mm (option: to 5000 mm)	60 to 300 mm
<b>Minimum media density</b>	0.85 g/cm <sup>3</sup>	0.75 g/cm <sup>3</sup>	0.85 g/cm <sup>3</sup>	0.8 g/cm <sup>3</sup>	0.85 g/cm <sup>3</sup>
<b>Operating temperature</b>	PP: 0 to +80°C		PVC: 0 to +60°C PP: 0 to +80°C	PE-HD: 0 to +60°C PVC: 0 to +60°C PP: 0 to +80°C PVDF: 10 to+ 130°C	cable: -10 to +70°C terminal housing: -10 to +120°C
<b>Contact type: Type S, O, W, M Type B</b>	stainless steel -20 to +150°C -10 to +100°C	stainless steel -20 to +150°C -10 to +100°C			
<b>Max. operating pressure</b>	25 bar	25 bar	0.5 bar	1 bar	15 bar
<b>No. of contacts</b>	1 to 3	1 to 6	1 to 3 (monostable)	1 to 6	1 to 3 (monostable)
<b>Smallest contact gap</b>	50 mm	50 mm	35 mm	50 mm	35 mm
<b>Electrical data</b>	see table 1 on page 1	see table 1 on page 1	see table 1 on page 1	see table 1 on page 1	see table 1 on page 1