

Operating Instructions

MAGTOP[®] V4... Magnetic Flap Indicator

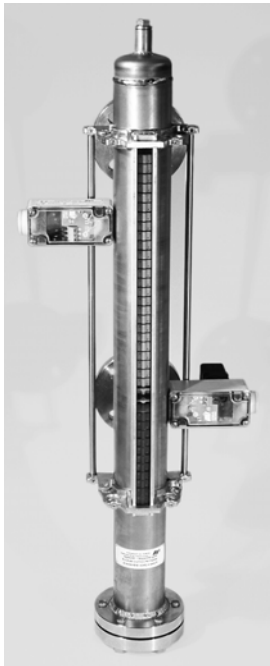

Safety Precautions

- In the event of large centre-to-centre spacing, the indicators are too heavy for one person to handle – **work must be performed by two persons in such cases.**
- Excessively high temperatures may occur after filling – **personnel must be protected against possible burns.**
- Make sure that threaded connections do not leak in order to assure that liquid is not discharged inadvertently during filling.
Danger of scalding
Danger of burns
- The device may only be operated under the conditions specified in the operating instructions!

Functions Description

MAGTOP magnetic flap indicators combine on-site visual display and fill-level control in a simple fashion. Their function is based upon the principle of communicating tubes, and they are connected to the side of the tank at the top and the bottom. The fill-level inside the tank is thus duplicated at the external standpipe.

A magnetised float is located inside the standpipe which causes indication of the tank's fill-level at the strip of magnetic flaps attached to the standpipe. The magnetic flap strip consists of a series of rotating magnetic plates with different colours at the front and back.

If the float has been correctly installed, the flaps rotate from yellow to red as the fill-level rises, and the height of the red column indicates the tank's fill-level. The float also actuates magnetic switches or continuous fill-level indicators which are attached to the standpipe.

Use for Intended Purpose

The MAGTOP magnetic flap indicator is used as a visual indicator for fill-levels at:

- Condensate containers
- Pressure booster systems
- Wine and sparkling wine tanks
- Beverage tanks
- Oil tanks

Utilised media must be of low viscosity, any may not contain any solid matter or magnetic particles. Utilised media may not tend to become tacky, resinous, encrusted or to crystallise, thus assuring free movement of the float. Magnetic particles may accumulate at the float, resulting in erroneous level indication and other malfunctions.

Use only IER float type M 3 or M 4!

Pumps and valves can be controlled if used in combination with MAGTOP SNAP... limit value switches.

Additional remote indication is possible in combination with NIVOMAT FSG... fill-level probes, and limit values can be established when used in combination with an SPC or our NIVOMAT FM 1019... and MV 424... measuring transducers.

Technical Data

Standpipe:

1.4571 stainless steel

Float:

1.4571 stainless steel

Type M3: for 0.8 density

Type M4: for 1.0 density (standard)

Process Interface:

DN20, DN25, DN32 or DN50 flange, either steel or 1.4571 stainless steel

Operating Temperature:

0 to +160° C

Operating Pressure:

16 bar at 20°C

8 bar at 160°C

Centre-to-Centre Distance:

Min. 600 mm

Max. 5000 mm

Magnetic Flap Rail:

AI/PC: max. +120° C

AI/PS: max. +160° C

Deaeration / Drain Screw:

G¼" (standard)

Discharge stopcock (optional)

Installation

- Check centre-to-centre distance.
- Remove the lower cover flange and seal.
- Slide the float into the standpipe with the "Top" symbol pointing up.
- Reinstall the sealing disc.
- Securely tighten the lower cover flange screws with a 17 mm open-end spanner or ring spanner.
- Tighten the 13 mm drain screw, making sure that it seals properly.
- If included, close the discharge stopcock before filling.
- Using suitable seals, mount the device to the tank in a stress-free fashion with appropriate nuts and screws.
- Fill the tank.
- Deaerate the MAGTOP V4 with the vent plugs if necessary.
- Tighten the upper vent plug.
- Check for leaks after filling.

Mounting Kit:

Special retaining clips (Al) for mounting:

- Magnetic flap rail
- Tracks for attaching adjustable MAGTOP Snap_U switches
- NIVOMAT FSG fill-level probe

Maintenance

- MAGTOP magnetic flap indicators are maintenance-free to a great extent.

If cleaning should become necessary:

- Depressurise the system, or close the shut-off valves.
- **Observe safety precautions for tanks containing hazardous or hot liquids!**
- Loosen the upper vent screw before emptying.
- Empty via the drain screw or the discharge stopcock.
- Carefully remove the lower flange, making sure that the float does not fall out of the standpipe.
- Clean as required.
- Reassemble as described under "Installation" above.
- Inspect flange seal and replace if necessary.

Accessories:

- **Contacts:**
See brochure: FG 6.2
- **FSG ... continuous fill-level probes:**
See brochure: FM 7.2

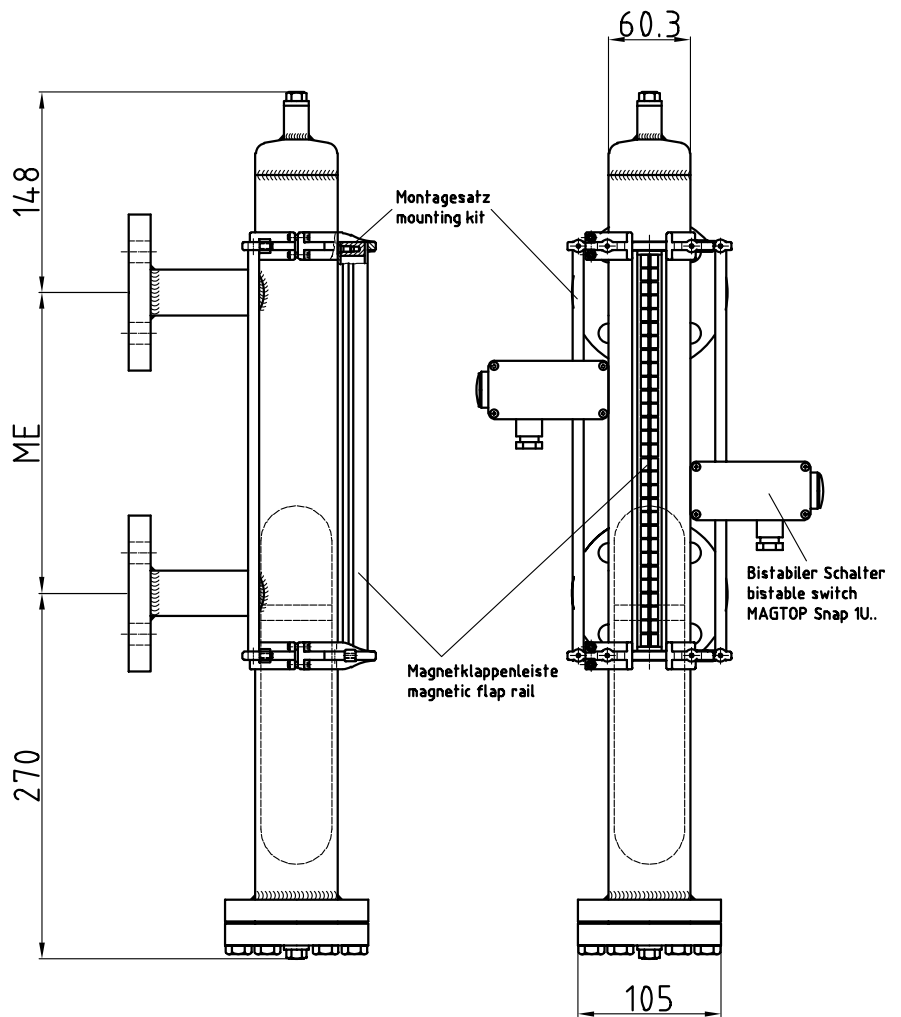

IER Meß- und Regeltechnik
Eberhard Henkel GmbH
Innstrasse 2
68199 Mannheim

Phone: +49 (0)621 84224-0 • Fax: +49 (0)621 84224-90
e-mail: info@IER.de • Internet: www.IER.de