

Operating Instructions

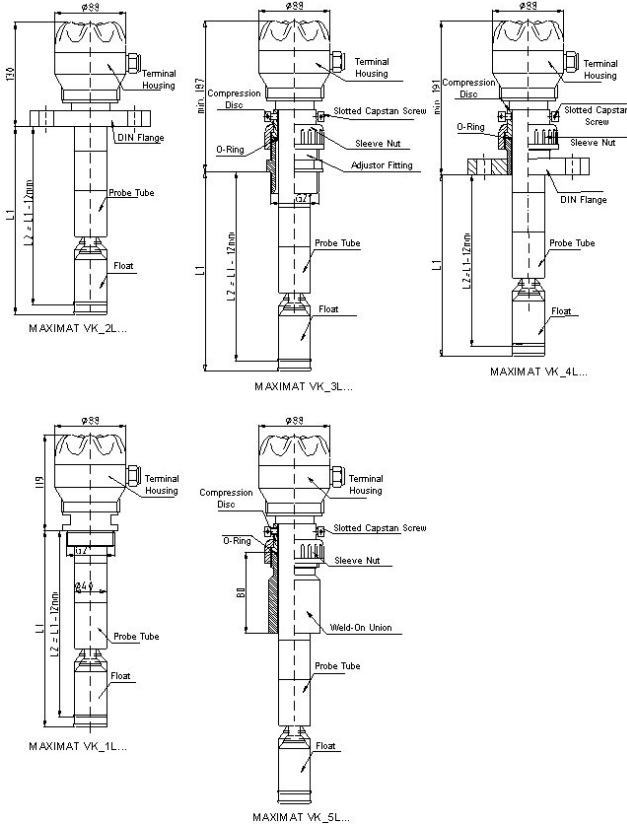

Compact Overfill Sensor, Float Type **MAXIMAT VK C...** with integrated measuring Transducer, DIBT Approval Z-65.11-355



Safety Precautions

- Installation, initial start-up and maintenance may only be performed by trained personnel! All applicable European and national regulations regarding installation of electrical equipment must be adhered to.
- The device may only be connected to supply power which complies with the specifications included in the technical data and on the serial plate!
- The device must be disconnected from all sources of power during installation and maintenance work!
- The device may only be operated under the conditions specified in the operating instructions!

Functions Description

The MAXIMAT VK C... compact overfill sensor is used as a fill-level limit switch for permanently installed containers used for the storage of non-flammable, water endangering liquids.

It is equipped with three different output circuits:

- A binary output for controlling a coupling relay, or the digital input of a PLC
- A 0 to 20 mA current output for controlling an analogue input channel, e.g. a programmed logic controller (PLC)
- Self-monitoring measuring circuit in combination with the MAXIMAT SHR C... measuring transducer with 2-wire connection

Note:

Only for liquids with density greater than **0.7g/cm³**

The MAXIMAT VK C... compact overfill sensor is used also for oil, emulsion and other non-conductive liquids.

Technical Data

Supply power

24 V DC \pm 10%

With current limiting or 250 mA fuse recommended

Connected load

Approx. 3 W

Ambient temperature

-20 to +60 °C

Container pressure

Atmospheric (0.8 to 1.1 bar)

Terminal housing

IP 65

Terminals

Screw terminals: IP 20

Max. wire cross-section: 2.5 mm²

Outputs

Binary output: +DO/-DO max. 20 mA / 24 V +AO / -AO

0 to 20 mA

Output for MAXIMAT SHR C... measuring transducer

DIP Switch

Operating Mode	DIP1	DIP2	DIP3	DIP4
Binary output	ON	ON	ON	OFF
Current output/PLC	OFF	OFF	OFF	OFF
MAXIMAT SHR C	OFF *	OFF *	OFF *	OFF *

* Default setting

Note:

Be sure to examine the DIP switch settings before switching supply power on!

Indicators

Green LED on the connector PCB:

- Run = LED illuminated
- Alarm / error = LED off

Measuring circuit for use with SHR C... transducer

Max. cable inductance: approx. 5 mH

Max. cable capacitance: approx. 0.5 μ F

Measuring circuit cable length

Max. 300 m

Min. wire cross-section: 0.5 mm²

CE mark

In accordance with low-voltage directive (73/23/EWG), EMC directive (89/336/EWG) and

- EN 50 082-2:1995
- EN 55 011 (class A):1998

DIBT Approval

Approval no. **Z-65.11-355** for overfill sensors and leakage sensors in accordance with WHG §19

Note:

The accompanying "General Building Supervisory Approval no. Z-65.11-355" is an integral part of the operating instructions and all stipulations contained therein must be adhered to!

Electrical connection:

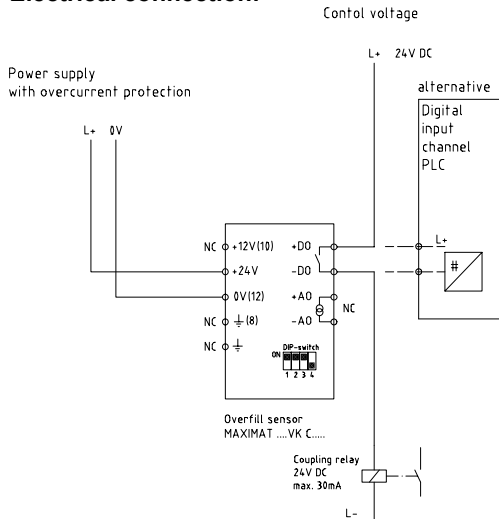

MAXIMAT VK C... binary output to coupling relay

Power supply with overcurrent protection

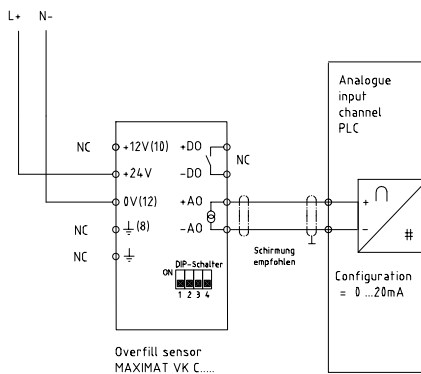

MAXIMAT VK C... current output to PLC analogue input

Logic
 OK = $I_m > 4 \text{ mA} \dots < 20 \text{ mA}$
 Fill level alarm = $I_m < 4 \text{ mA}$
 Defective = $I_m < 4 \text{ mA}$ oder $> 20 \text{ mA}$

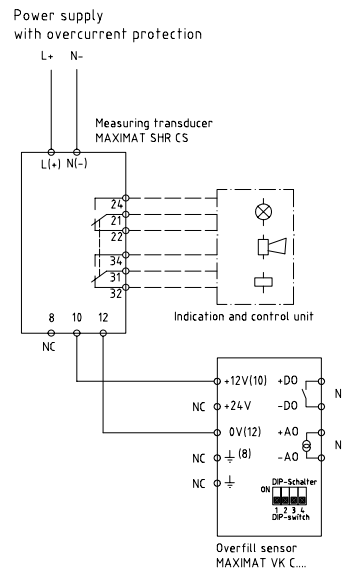

MAXIMAT VK C... to MAXIMAT SHR CS measuring transducer

Power supply with overcurrent protection

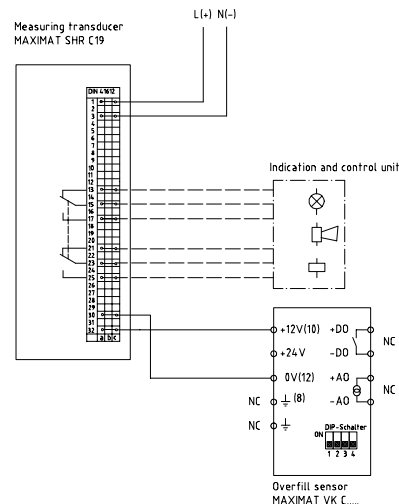

MAXIMAT CK C... to MAXIMAT SHR C19 transducer

Adjustment Instructions

The maximum allowable fill-level of any given tank can be determined, for example, in accordance with TrbF 280 no. 2.2. Triggering level A is then calculated in accordance with attachment 1, or the approval guidelines for overfill inhibitors (ZG-ÜS). Dribbling quantities and switching delay times must be taken into consideration. Switching delay time can be adjusted at the MAXIMAT SHR C measuring transducer within a range of 0.3 to 3 seconds.

Installation length L determines the fill-level monitor's triggering point.

Dimensions are calculated as follows:

- H = tank height
- A = triggering level
- B = connector
- E = immersion depth, table E
- S = triggering point

$$L = H - A + B + E + 3$$

$$S = L - E - 3$$

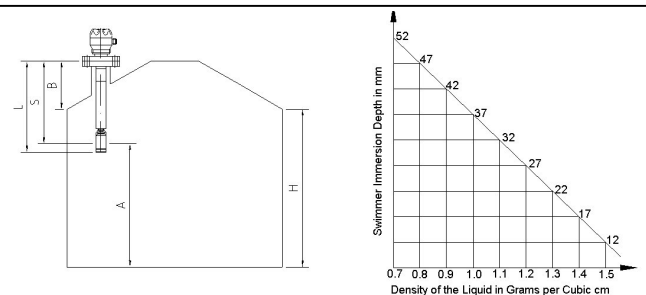

Guide tubes included with **MAXIMAT VK.3L** and **MAXIMAT VK.4L** adjustable level monitors are supplied 50 mm longer than dimension L, so that the fill-level monitor can be adapted to correspond to triggering level A during installation. It is thus possible to readjust dimension L. After the triggering point has been set, the locking screws are tightened and sealed against tampering. Due to the fact that this seal is not removed during periodic testing, dimension L is always fixed, i.e. no readjustment is necessary