

Operating Instructions

GNR5C Sight-Glass Level Controller

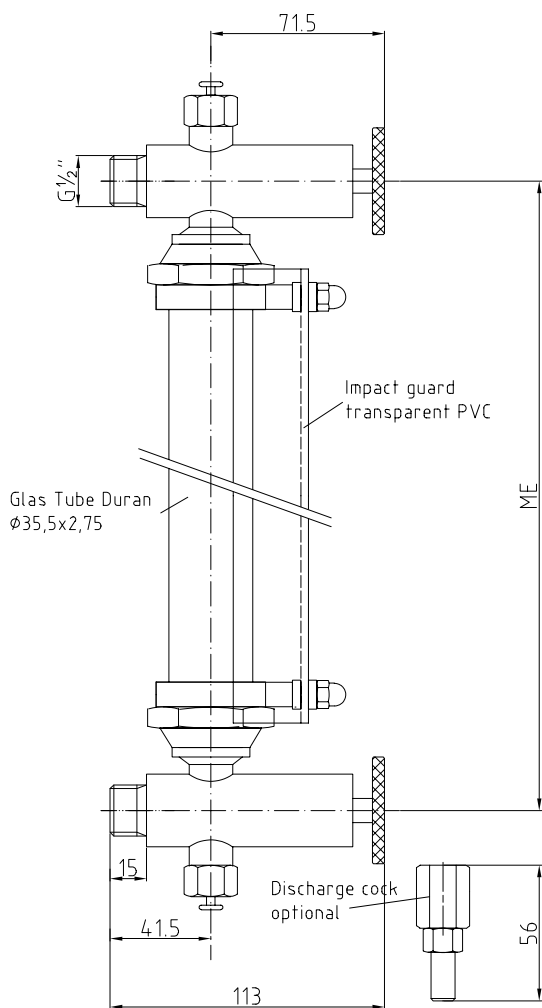

Figure. 1: GNR5C with threaded connectors and 2 BSM500W_/d34 bistable switches

Attention!

- Use with low-viscosity media only which neither tend to become sticky or encrusted, nor precipitate crystals. Media may not contain magnetic particles (e.g. metal chips).
- Use only type S5/25d floats.
- The float must be installed with the “TOP” marking at the top.
- Observe maximum temperature and pressure ratings.
- Do not allow to tilt during installation! Centre-to-centre distance and squareness of the flanges or threaded connectors should be checked before installing the glass tube.
- Observe correct installation order for sealing rings (see drawing next page).

Functional Principle:

The GNR5C sight-glass level controller is mounted to the side of a vessel or a tank. The gauge is filled with liquid media to the same level as the tank via two shut-off valves.

A magnetic float is located within the standpipe, which indicates the current fill-level.

The glass tube is protected against damage with a semicircular impact guard made of transparent PVC.

The magnetic float can also be used to activate optionally available BSM 500 W... bistable switches (see also data sheet SU0090).

Technical Data

Standpipe	Glass, DURAN. 34.5 x 2.75 mm
Float	Polypropylene (PP), type S5/25d
Fittings	Stainless steel 1.4404/316L with EPDM sealing
Seals	Silicon rubber
Operating temperature	0 to + 110° C (120° C intermittent)
Operating overpressure	max. 1 bar
Length (flange centre-to-centre)	300 to 2000 mm
Mounting	Flange: DIN 2642 DN 25 PN, steel alternatively DN20 PN10 steel or threaded connector: G1/2" or G1" stainless steel 1.4404
Discharge stopcock (optional)	
Electrical components	BSM 500 W... bistable switch with 34 mm dia. pipe clamp

Installation Procedure:

GNR5C with Flanges:

- Mount the top and bottom shut-off valves to the tank flanges using suitable sealing materials. Do not yet fully tighten the screws.
- Insert the 11 x 12 x 5 mm silicon discs into the shut-off valves.
- Push the hose clamps for fastening the impact guard and the sleeve nuts, along with the silicon rings (which have been snapped into place inside the nuts), over the standpipe (see figure 2).
- Insert the standpipe between the shut-off valves making sure that is square.
- Check the length of the glass tube! The tube must fit flush against the silicon discs. Loosen the flange screws if necessary to correct distance and squareness.
- Retighten the flange screws.
- Push the sleeve nuts up to the shut-off valves and tighten (46 mm open-end wrench). Tighten the sleeve nuts!
- Attach BSM 500 W... bistable switches if used (the cable gland must always point down).
- Mount the transparent impact guard (see figure 2).
- After the vessel has been filled, check all fittings for leaks!

GNR5C with Threaded Connectors:

- Mount the top and bottom shut-off valves to the threaded connectors at the tank using suitable sealing materials.
- Insert the 11 x 12 x 5 mm silicon discs into the shut-off valves.
- Push the hose clamps for fastening the impact guard and the sleeve nuts, along with the silicon rings (which have been snapped into place inside the nuts), over the standpipe (see figure 2).
- Insert the standpipe between the shut-off valves making sure that is square.
- Check the length of the glass tube! The tube must fit flush against the silicon discs. Correct if necessary.
- Push the sleeve nuts up to the shut-off valves and tighten (46 mm open-end wrench). Tighten the sleeve nuts.
- Attach BSM 500 W... bistable switches if used (the cable gland must always point down).
- Mount the transparent impact guard (see figure 2).
- After the vessel has been filled, check all fittings for leaks!

Maintenance:

If used for its intended purpose, the GNR5C is maintenance-free.

However, the magnetic float accumulates any magnetic particles which may be present in the medium over a period of time. In order to prevent operating errors, the float should be cleaned to remove magnetic particles at regular intervals.

In order to clean the float, close both shut-off valves and empty the medium from the glass tube by opening the stopcock.

Check the condition of the seals during reassembly and replace if necessary.

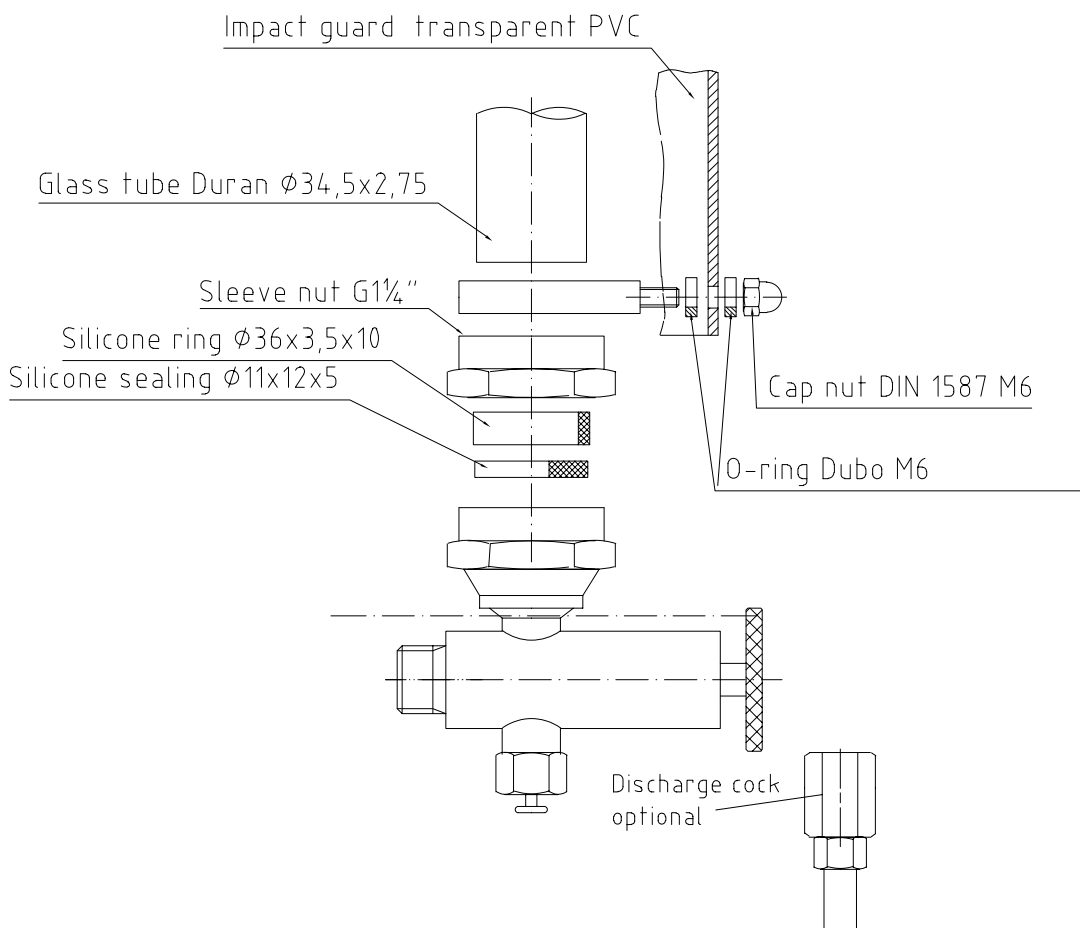

Fig.. 2: GNR5C with Threaded Connectors:



IER Meß- und Regeltechnik
Eberhard Henkel GmbH
 Innstrasse 2
 68199 Mannheim

Tel. +49-(0)621-84224 0 • Fax: +49-(0)621-84224 90
 e-mail: Info@IER.de • Internet: www.IER.de