

EVEREST 214 Measuring Amplifier, 4 Limit Value Relays, Pulse Timer integrated with 2 Input Channels for 0/4 to 20 mA Sensors



Safety Precautions

- Installation, initial start-up and maintenance may only be performed by trained personnel! All applicable European and national regulations regarding installation of electrical equipment must be adhered to.
- The device may only be connected to supply power which complies with the specifications included in the technical data and on the serial plate!
- Do not open the housing!
- The device must be disconnected from all sources of power during installation and maintenance work!
- The device may only be operated under the conditions specified in the operating instructions!

Functions Description

Measuring amplifier for two sensors with 0/4 to 20 mA signal, 2 or 3-wire connection

- μ -Processor controlled
- 24 V DC sensor supply power
- Integrated pulse timer, 1 second to 24 hours, e.g. for MEMPRO ventilation control
- 2 scalable measurement inputs (measured value window)
- Measurement input E1 or E2 can be individually assigned to each of the output relays, A1 through A4.
- Adjustable delay time for each limit value relay
- Adjustable hysteresis for each limit value relay
- Adjustable filter time of up to 3 seconds
- Normally closed or normally open function can be selected for each limit value relay

CE Mark

In accordance with low-voltage directive (73/23/ECC), EMC directive (89/336/ECC)

Technical Data

Supply power:

230 V / 50 Hz

Connected load:

Approx. 2 VA

Ambient temperature:

-10 to +45° C

Limit value contacts:

3+1 floating contacts

3 with common root

1 floating contact can be selected as a clock generator output (can be switched back and forth between NC and NO function)

Output relay switching capacity:

250 V AC, 3.0 A / 30 V DC, 1.0 A

Caution: Contacts are not protected against overload – use external protective device!

Housing:

22.5 x 100 x 122 mm, IP 40, for

Top-hat rail: 35 x 7.5 mm (DIN EN 50 022)

Caution: Contact protection per DIN EN 61010-1 is only assured when installed to a closed housing with at least IP 54 protection.

Terminals:

Screw terminals, max. 1.5 square mm

Measuring circuit:

2 inputs: 4 to 20 mA (default setting)

Scalable to 0 to 25 mA

Measuring accuracy:

Better than 1% \pm 1 digit

Display resolution:

1%

Measured value filter:

Adjustable from 0.1 to 3 seconds

Reset hysteresis:

Adjustable from 0 to 99%

Sensor power supply:

24 V DC, max. 50 mA (2-wire connection)

Indicators:

Measured value:

2-place, 7-segment LED display

Switching status:

4 LEDs = limit value relays

1 LED = input 1 or input 2

Settings:

Rotary switch and pushbutton on the front panel

Maintenance

The device is maintenance-free if used for its intended purpose.

EVEREST 214 Measuring Amplifier

Controls:

Rotary switch ±:

The desired relay (1 through 4), is selected in menu level 1.
The desired values are selected in menu levels 2 through 6.

Pushbutton:

Used to select submenus 1 through 6.
Pushing the button in submenu 6 returns the display to menu 1.

Note:

If none of the controls are activated for 15 seconds, the device is automatically returned to the measured value display (menu 0).

Output relays 1 through 4:

Yellow LED lights up = relay pulled in = contact closed

Limit value:

Setting range from 0 to 100% relative to the selected mA Min-Max range
Default setting: A1 = 80%, A2 = 60% A3 = 40% A4* = 20%

Delay time:

Adjustable from 0.1 to 10 seconds
Limit value violation → wait for delay time to elapse → the relay is then switched.
Default setting: 0.1 seconds

Hysteresis:

Setting range: 0 to 99%
The output relay is not switched back until the measured value is **fallen short of** by the selected percentage value.
Default setting: 1%

NC-NO selection:

NO = normally open = contact is open as long as the measured value is less than the selected threshold value

NC = normally closed = contact is closed as long as the measured value is less than the selected threshold value

Default setting: NO

Note:

All relays are open in the event of power failure or device malfunction.

Assigning input E1 or E2 to the limit value relay:

The measured value from input E1 or E2 can be assigned individually to each relay output (A1 through A4).

Default setting: E1

Overranging display:

Measuring signal > mA max. value → digital display = nnn
Measuring signal < mA min. value → digital display = uuu

Pulse Timer:

The pulse timer is switched on as soon as **on and off-time** is set to a value of **greater than 0**.

* Setting values for **limit value** relay 4 are rendered inactive as a result.

On-time:

The contact at relay 4 remains closed as long as the selected on-time has not yet elapsed.

Setting range: 1 second to 24 hours

Available setting values:

0*, 1, 2, 5, 10, 30 s: **No** decimal point is illuminated.

1, 2, 5, 10, 30 min.: **The right** decimal point is illuminated.

1, 2, 3, 6, 12, 24 hours: **The left** decimal point is illuminated.

Default setting: 0

Off-time:

The contact at relay 4 remains open as long as the selected off-time has not yet elapsed.

Setting values same as above

Default setting: 0

Note:

After power failure, the device is rebooted and the program starts with on-time.

If on or off-time is changed during operation, the new on or off-time becomes immediately effective.

Scaling inputs 1 and 2:

mA min. value:

Setting range: 0 to 24 mA

Default setting: = 4 mA

mA max. value:

Setting range: 1 to 25 mA

Default setting: = 20 mA

The percentage display can be assigned to a range of the mA measuring signal in the *Scaling* menu.

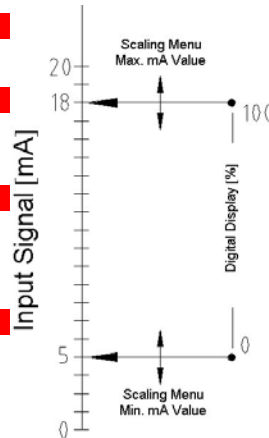

Example:

Measuring signal 5 mA = display of 0%
Measuring signal 18 mA = display of 100%

Settings required to this end:
Menu: *Scaling E1 / mA min.* = 5
Menu: *Scaling E1 / mA max.* = 18

Filter time:

Filter for attenuating measured value fluctuations and interference

Integration time: adjustable from 0.1 to 3 seconds

Default setting: 0.1 seconds

Reset to default settings:

Switch supply power on.

Within 3 seconds (i.e. during the test routine), press and hold the pushbutton for approximately 5 seconds:

The display counts up: 1, 2, 3, 4 ... 99, St...

→ All settings are returned to their default values.

Switching on supply power:

After supply power has been switched on, the device starts a test routine during which all LEDs and the digital display are activated (lamp test). After approximately 1 second, the software version is briefly displayed.

The display is then switched to menu level 0 and the measured value display for E1.

EVEREST 214 Measuring Amplifier

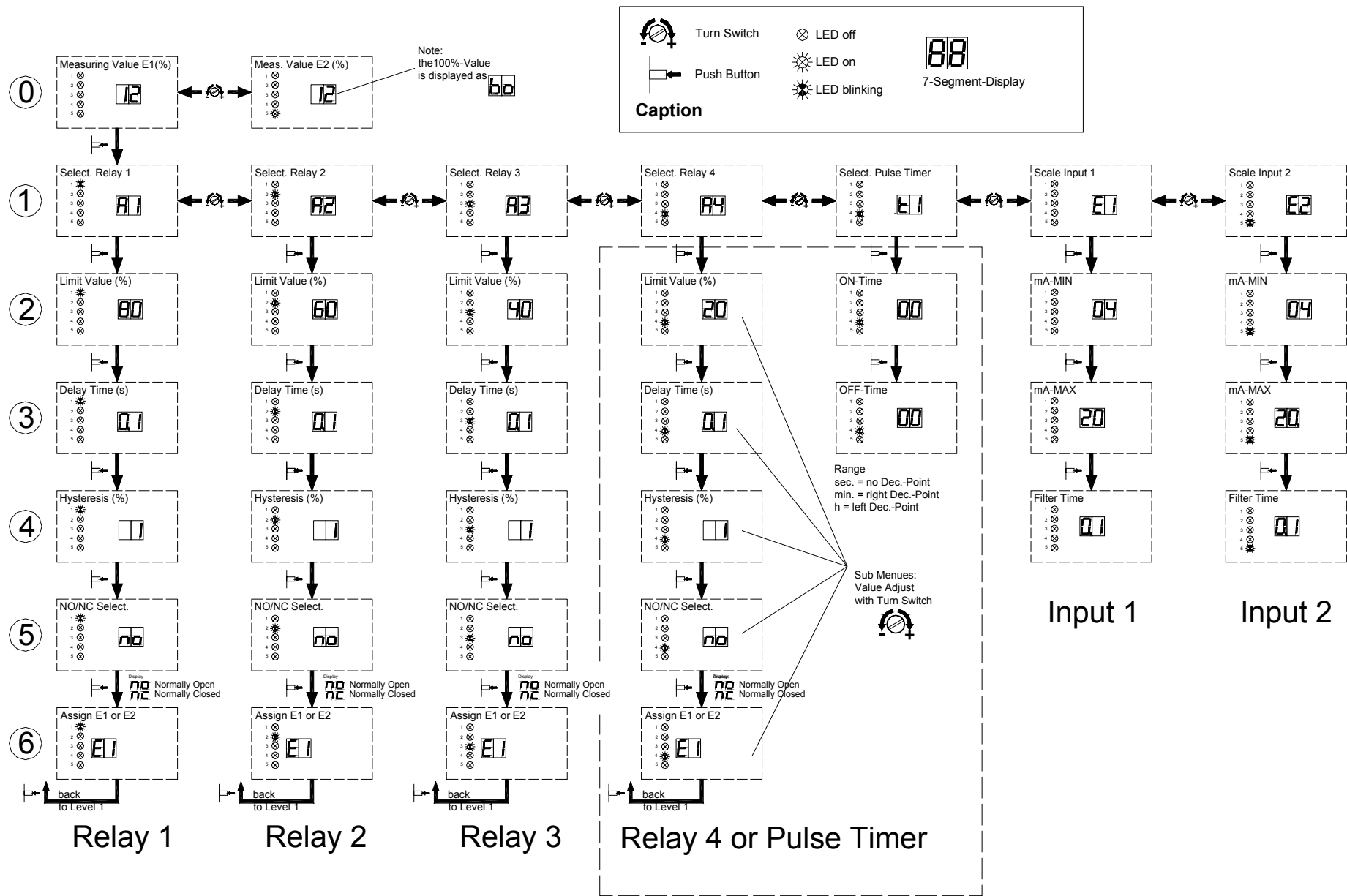

EVEREST 214 Measuring Amplifier

Electrical Connection

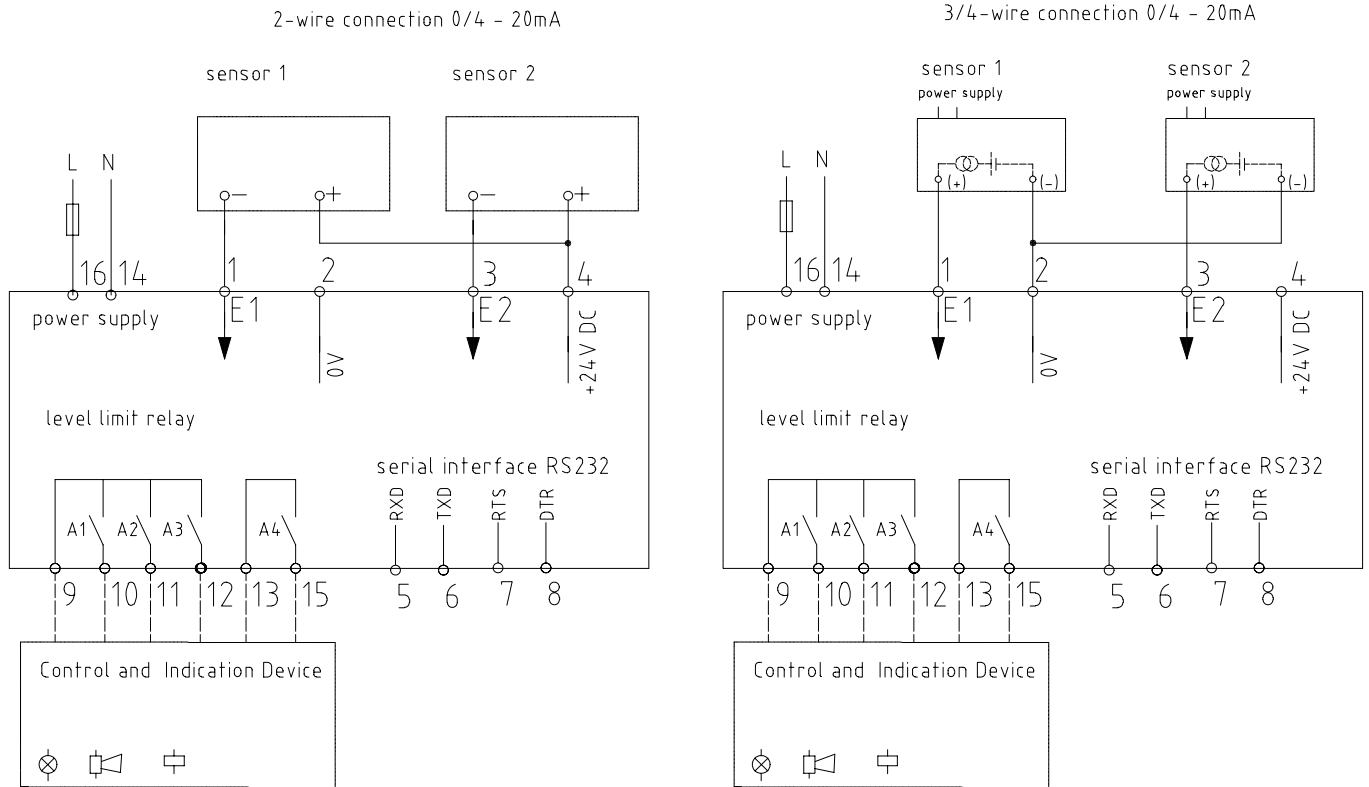

Sample Schematic for Sensors with 2, or 3/4-Wire Connection



IER Meß- und Regeltechnik
Eberhard Henkel GmbH
 Innstrasse 2
 68199 Mannheim

Tel. +49 (0)621 84224-0 • Fax: +49 (0)621 84224-90
 e-Mail: info@IER.de • Internet: www.IER.de