

Compact Leakage Sensor **MAXIMAT LW C25 ...**

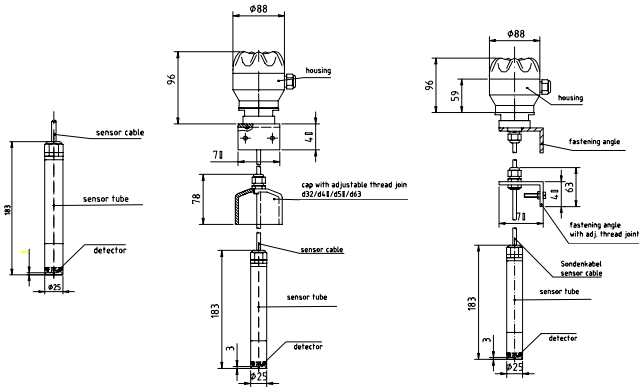

MAXIMAT
LW C25 Z0

MAXIMAT LW C25 ZD

MAXIMAT LW C25 ZK

Safety Precautions

- Installation, initial start-up and maintenance may only be performed by trained personnel! All applicable European and national regulations regarding installation of electrical equipment must be adhered to.
- The device may only be connected to supply power which complies with the specifications included in the technical data and on the serial plate!
- The device must be disconnected from all sources of power during installation and maintenance work!
- The device may only be operated under the conditions specified in the operating instructions!

Functions Description

The MAXIMAT LW C25 Z ... compact leakage sensor is used as a leakage monitoring device for permanently installed containers used for the storage of non-flammable, water endangering liquids.

It is equipped with three different output circuits:

- A binary output for controlling a coupling relay or the digital input at a PLC
- A 0 to 20 mA current output for controlling an analogue input channel, e.g. a programmed logic controller (PLC)
- Self-monitoring measuring circuit in combination with the MAXIMAT SHR C... measuring transducer with 2-wire connection

Applications:

Stored liquids may not tend to precipitate insulating or conductive sediments.

CE-Mark:

In accordance with low-voltage directive (73/23/EWG), EMC directive (89/336/EWG)

Technical Data

Supply power

24 V DC \pm 10%

Power supply with current limiting or 250 mA fuse recommended

Connected load

Approx. 3 W

Ambient temperature

-20 to +60 °C

Container pressure

Atmospheric (0.8 to 1.1 bar)

Outputs

- Binary output: +DO / -DO max. 30 mA at 24 V DC
- Current output: +AO / -AO, 0 to 20 mA
- Output for MAXIMAT SHR C... measuring transducer

MAXIMAT LW C25 ZD and ..K

Terminals

Screw terminals, IP 20

Max. wire cross-section: 2.5 mm²

Terminal housing

IP 65

DIP Switch

Operating Mode	DIP1	DIP2	DIP3	DIP4
Binary output	ON	ON	ON	OFF
Current output	OFF	OFF	OFF	OFF
MAXIMAT SHR C	OFF *	OFF *	OFF *	OFF *

* Default setting

Note:

Be sure to examine the DIP switch settings before switching supply power on!!!

Indicators

Green LED on the connector PCB:

- Run = LED illuminated
- Alarm / error = LED off

Measuring circuit for use with SHR C... measuring transducer

Max. cable inductance: approx. 5 mH

Max. cable capacitance: approx. 0.5 μ F

Measuring circuit cable length

Max. 300 m

Min. wire cross-section: 0.5 mm²

DIBT Approval

Approval no. Z-65.40-316 for overfill inhibitors and leakage sensors in accordance with WHG §19

Note:

The accompanying "General Building Supervisory Approval no. Z-65.40-316" is an integral part of the operating instructions and all stipulations contained therein must be adhered to!

Mechanical Installation of the Leakage Sensor

The leakage sensor's probe is suspended such that it hangs into the catch basin of the storage tank to be monitored. The probe may make contact with the outside wall of the catch basin, or may stand on its floor. The cable must be secured such that the probe is always positioned vertically. The connector cable between the probe and the measuring transducer is pulled through the Pg fitting mounted to the bracket or the cap until the portion of the cable inside the catch basin holds the probe in the vertical position. When installed in a free-hanging fashion, it must be assured that the connector cable is only pulled far enough through the adjuster fitting to allow for a maximum clearance of 45 mm between the probe and the catch basin floor, so that the leakage alarm is triggered at a maximum fill-level of 50 mm.

If the MAXIMAT LW C25 Z0 variant is used, other suitable mounting components must be utilised in an appropriate fashion.

Adjustment Notes

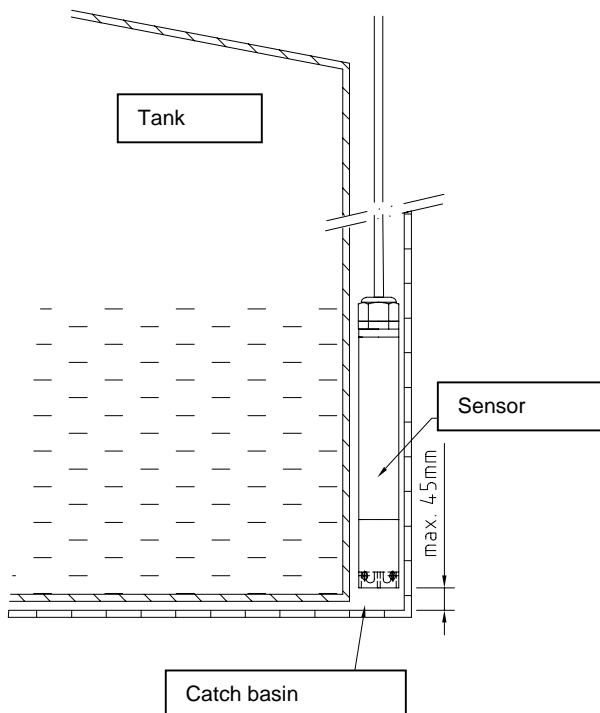

Installation Example:

Storage Tank Leakage Sensor

The leakage probes are installed inside catch basins. If the bottom of the probe contacts the floor of the catch basin, the alarm signal is triggered when the liquid reaches a fill-level of approximately 5 mm. For applications involving storage tank catch basins, the probe must be installed such that the alarm signal is triggered at a fill-level of 50 mm or less.

Periodic Testing

The leakage probe must be tested for correct functioning at reasonable intervals, although not less than once a year. It is the sole responsibility of the user to select the utilised test type, as well as a testing interval within the prescribed timeframe.

Testing must be performed which substantiates flawless functioning of the leakage sensor, and correct interaction with all other associated components. This is assured by means of suitable simulation of a leak, or the physically measured effect which causes triggering of the alarm signal. If correct functioning of the leakage sensor can be established by other means (exclusion of function impairing errors), testing can be executed by simulating the appropriate output signal. Further details concerning test methods are included, for example, in directive VDI / VDE 2180, page 4.

Leakage Sensor Materials

In the event of a tank leak, the leakage sensor (probe and probe tube) comes into contact with the stored liquid, or vapours and condensate resulting there from. For this reason, leakage sensor materials must be selected which are adequately resistant to the liquid to be monitored.

Component	Material
Measuring probe	Glass carbon
Probe tube	Plastic (polyethylene, PE)
Cap, 63 mm dia. (... CZD)	PVC (polyvinyl chloride)
Bracket	PVC (polyvinyl chloride)
Pg fitting	PA (polyamide)
Press-fit seal at Pg fitting	NBR (perbunan)
Cable from probe to measuring transducer	PVC control cable

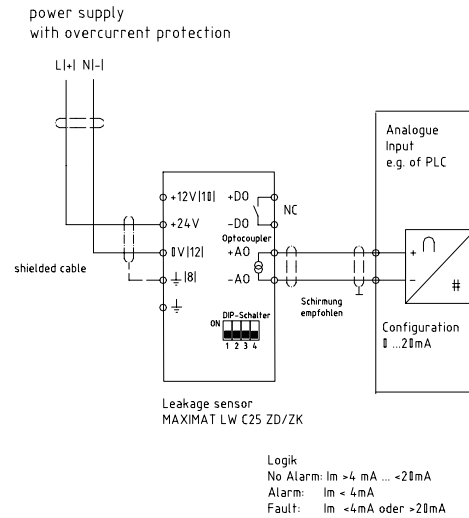
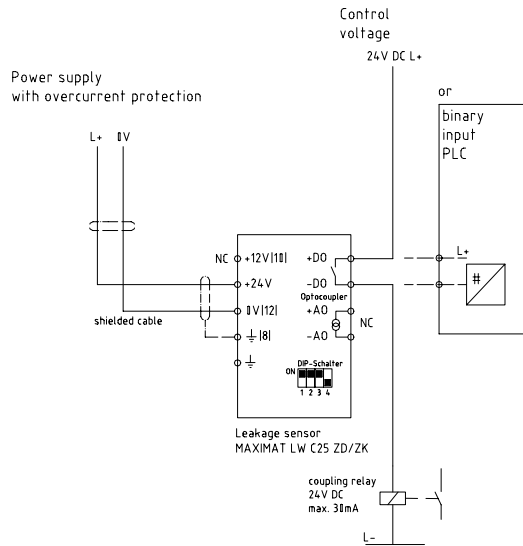

MAXIMAT LW C25 Z... binary output to coupling relay or PLC MAXIMAT LW C25 Z current output to PLC analogue input

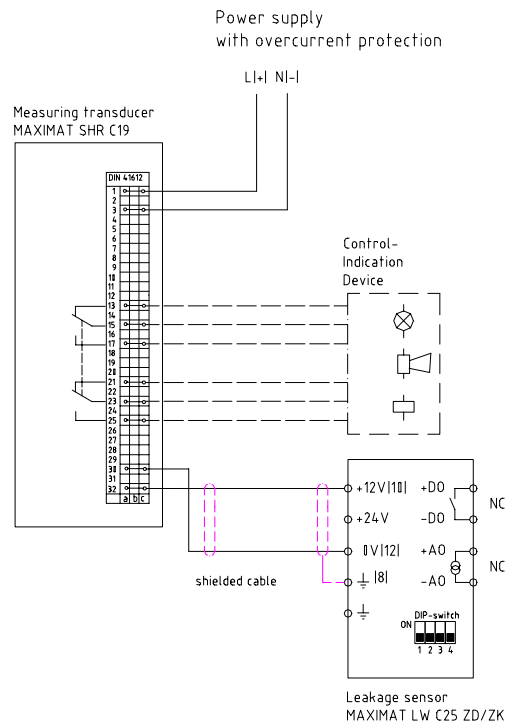
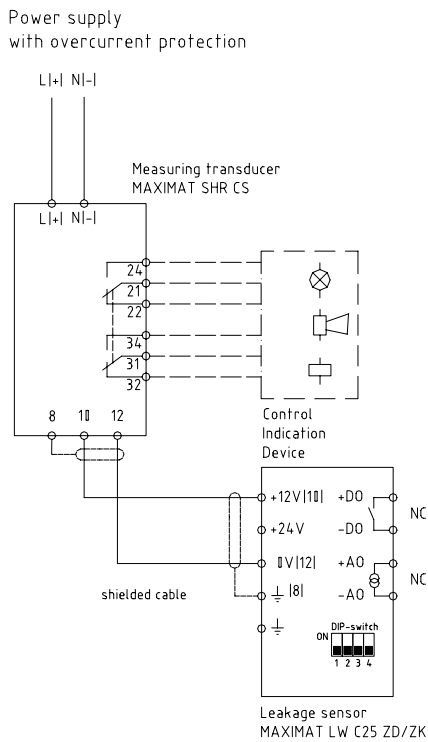

MAXIMAT LW C25 Z...
to MAXIMAT SHR CS measuring transducer

MAXIMAT LW C25 Z
to MAXIMAT SHR C19 measuring transducer

