

ES1S Electrode Controls



Safety Precautions

- The device may only be connected to supply voltage which is in compliance with the technical data shown on the serial plate!
- Installation, initial start-up and maintenance may only be performed by trained personnel!

Technical Data

Power Supply

230 V AC, +/-10%, 50-60 Hz
 Optional: 24, 115 V AC or 24 V DC +/-10%
 See serial plate on device.

Power Consumption

approx. 2 VA

Ambient Temperature

-15 to +45°C

Housing

22.5 x 75 x 100 mm, IP40
 Quick mount to standard rail
 DIN EN 50 022 (35 x 7.5 mm top-hat rail)
 or 88 x 150 x 130 mm, IP55 for surface mounting

Terminals

IP20, screw terminals
 Conductor cross-section: max. 2.5 square mm

Measuring Circuit

Electrically isolated
 Alternating voltage < 6V / < 2 mA

Cable Length

max. 300 m (for highly conductive liquids)
 See figure 1.
 min. conductor cross-section: 0.5 square mm, shielded

Measuring Functions

MIN-MAX control,
 MIN control or MAX control

Sensitivity

Two adjustable ranges
 1 to 70 kΩ / 5 to 150 kΩ
 Can be selected / adjusted with DIP switch / potentiometer
 (full left turn / anti clockwise = min. sensitivity)

Reset Hysteresis

approx. 20% of the selected sensitivity value

Relay Outputs

2 ea. floating changeover contacts
 AC: max. 250 V, 5 A, 500 VA
 DC: max. 125 V, 1 A, 40 W

Operating Principle

Working current / closed-circuit current
 selectable with DIP switch

Delay

ON delay / OFF delay: 0.5 to 3 sec.
 adjustable with potentiometer (full left = approx. 0,5 sec.)

Status Indication

1 ea. "on" LED, 1 ea. switching status LED

CE Mark of Approval

In accordance with low-voltage directive 2006/95/EG,
 EMC directive (89/336/EWG) and

Applications Limits

Conductive liquid-level controls are **not** suited for liquids which contain oil or grease, or which may cause electrically insulating deposits at the electrodes.

Functional Description

ES1S electrode controls function in accordance with the conductive principle, i.e. the electrical conductivity of the liquid to be monitored is used to establish an electrical connection between the immersed electrodes.

Measuring Ranges

ES1S electrode controls can be used for liquids with a resistance between the electrodes of less than 150 kΩ (observe maximum cable length!).

Controls

Intermittent switching (minimum / maximum liquid level) with three electrodes

Monitoring of a specific fill level (overflow / empty alarm) with two electrodes. A metal container can be used as the reference electrode.

Electrical Connections

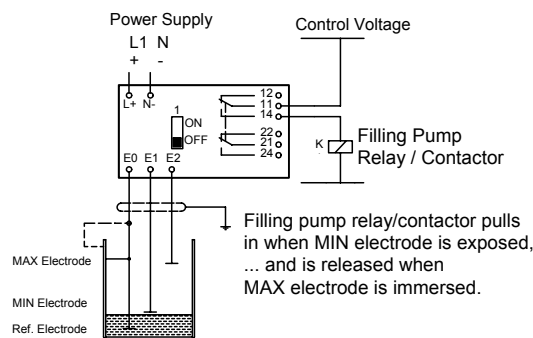

Wiring Diagram 1: Filling the Container

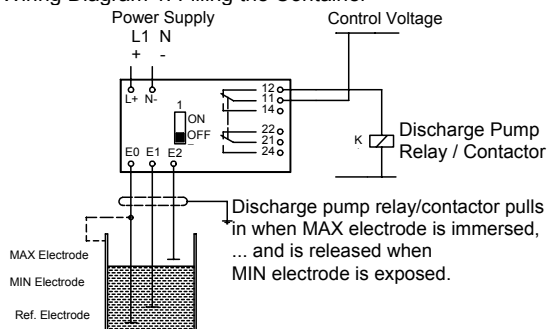

Wiring Diagram 1: Draining the Container

Electrical Connections

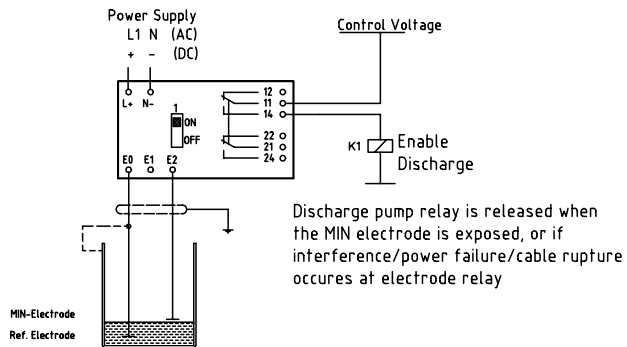

Wiring Diagram 2: Empty Alarm

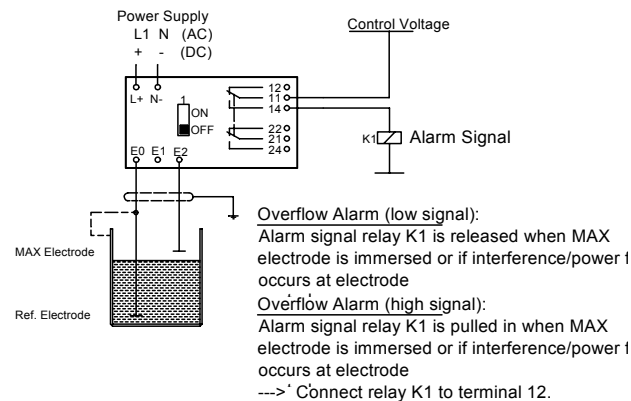

Wiring Diagram 3: Overflow Alarm

Initial Start-Up

- Check for correct supply voltage! Observe data printed on the serial plate!

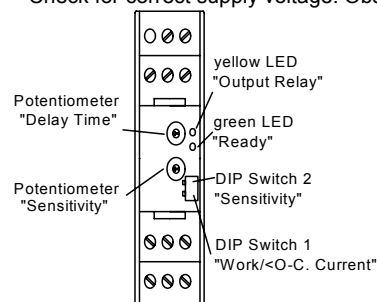

- Make sure that polarity is not reversed if DC supply power is used!
- Check electrode connections!

Adjustments

The transparent front panel can be pried out with a screwdriver.

Sensitivity: Potentiometer P1 and DIP switch S2 are used to adjust sensitivity to the conductivity of the liquid to be monitored.

Procedure: The poorer the conductivity of the liquid, and the greater the distance between the electrodes, the higher the sensitivity must be adjusted.

Attention: Erroneous switching may occur if sensitivity is set too high!

Working Current / Closed-Circuit Current: DIP switch S1

ON delay / OFF delay: Potentiometer P2

Flutter suppression is provided in order to prevent excessive switching in the event of disturbances at the surface of the liquid.

Potentiometer	Full Left	Full Right
P1: Sensitivity	min.	max.
P2: Delay	approx. 0.5 sec	approx. 3 sec

DIP Switch	ON	OFF
1	working current	closed-circuit current
2	high sensitivity 5 - 150 kΩ	low sensitivity 1 - 70 kΩ

Status Indication

Green LED lights up	ready for operation
Yellow LED lights up	output relay pulled in

Response when Supply Power is Switched On

Setting	MIN Immersed	MIN+MAX Immersed	MIN+MAX Exposed
Open-circuit current + no DT	0	0	0 -> 1
Working current + no DT	0 -> 1	0 -> 1	0
Open-circuit current + DT	1 ->DT->0	1 ->DT->0	0 -> 1
Working current + DT	0 ->DT->1	0 ->DT->1	0

0 = Relay released
1 = Relay pulled in
DT = Delay time

Mounting in electrical cubicles and boxes

cubicles with increased inner temperature:
notice the power loss -->
distances between the relays not less than 0,5 cm!

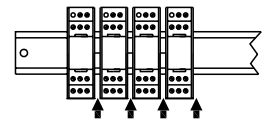

Operating Range

The capacitive resistance of long cables reduces the sensitivity of the electrode controls.

A typical, shielded, 3 conductor PVC cable has a capacitance of approx. 100 pF per metre. This results in an operating range which is dependent upon cable length and the resistance of the liquid in accordance with the following diagram:

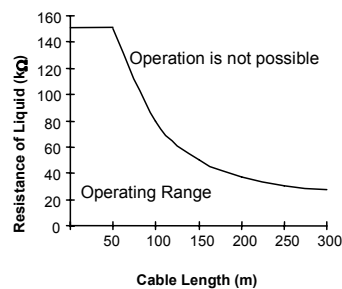

Figure 1: Operating Range

Maintenance

If the device is used for its intended purpose, no maintenance is required.

Troubleshooting

Green LED does not light up.	<ul style="list-style-type: none"> No supply power Device is defective
Yellow LED lights up, but the relay does not pull in. ¹	<ul style="list-style-type: none"> Measurement cable is interrupted Liquid is not conductive enough Contaminated electrodes (insulating layer) Device is defective
Yellow LED lights up, but the relay does not release	<ul style="list-style-type: none"> Short-circuited measurement cable Electrodes bridged with conductive contamination Sensitivity is set too high Device is defective

¹ DIP switch 1 in "working current" position